

Nema 42 Size - 2 Phase Hybrid Step Motor



Features

- High Torque
- High Acceleration Performance
- Able to withstand Higher Loading
- Longer Life span

General Specifications

- Step Angle : 1.8°
- Insulation Class : B
- No of Motor Leads : 4

Mechanical Dimensions (mm)

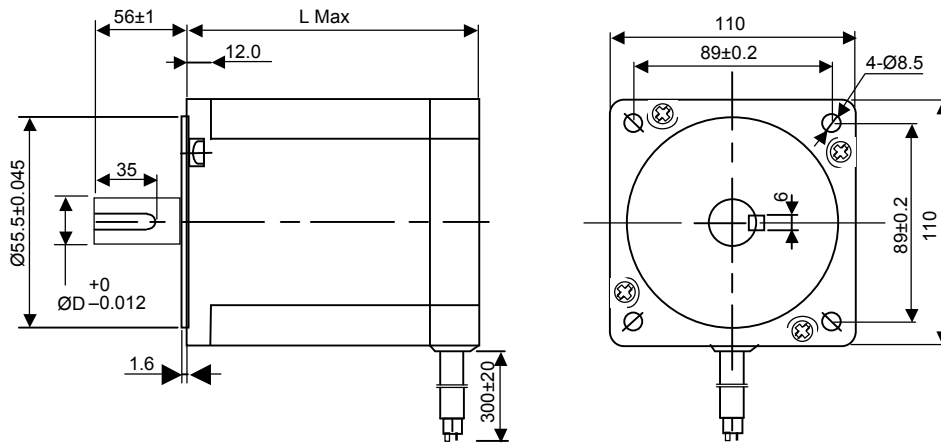

Wiring Diagram

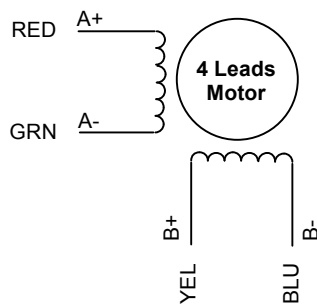

Motor Connection

Electrical Specifications

Model	Holding Torque (kgcm)	Current/Phase (A)	Resistance/Phase (Ω)	Inductance/Phase (mh)	Detent Torque (Kgcm)	Rotor inertia (Kg-cm ²)	Weight (kg)	Length Lmax (mm)	Shaft ØD (mm)	Keyway (mm)
PSM110HS2A115-2P	120	6	0.47	7	3	6	5.8	115	19	3 x 35
PSM110HS2A150-2P	200	6	0.9	16	6	11	8.4	150	19	3 x 35
PSM110HS2A165-2P	240	6	0.65	14	7.5	13	9.5	165	19	3 x 35